



Contents

CPU Modules.....	2
Input/Output Modules.....	5
Power Supply Modules	7
Power Supply Module PP 00 011.....	7
Termination modules.....	9
Termination Module ST 00 011.....	9
Analog Input Modules	11
Analog Input Module AI 02 031.....	12
Analog Input Module AI 02 041.....	17
Analog Input Module AI 04 051.....	19
Analog Input Module AI 04 011.....	22
Analog Input Module AI 04 081.....	24
Analog Output Module AO 02 011.....	26
Digital Input Modules	28
Digital Input Module DI 08 011	28
Digital Output Modules.....	31
Digital Output Module DO 08 011	31
Counter Modules	33
Counter Module DA 01 011.....	33
Communication Processor Modules.....	40
Communication Processor Module CP 01 011.....	40



Regul R200 Programmable Logic Controller – Data Sheets

CPU Modules

Central processor modules perform following functions:

- Logical data processing and control signals output in accordance with the user's application program
- Data exchange with the interface and input/output modules
- Data exchange with third party equipment by means of built-in interfaces
- Checking of system configuration and working capacity of functional modules

The central processor module includes a power supply module.

Part number	Module description
R200 CU 00 021	Central processor unit module ARM Cortex-Ax, 512 Mb RAM, 1Gb Flash, RS-232, RS-485, 1x Ethernet RJ-45
R200 CU 00 031	Central processor unit module ARM Cortex-Ax, 512 Mb RAM, 1Gb Flash, RS-232, RS-485, 1x Ethernet RJ-45
R200 CU 00 041	Central processor unit module ARM Cortex-Ax, 512 Mb RAM, 1Gb Flash, RS-232, RS-485, 2x Ethernet RJ-45, GPS/GLONASS
R200 CU 00 061	Central processor unit module ARM Cortex-Ax, 512 Mb RAM, 1Gb Flash, RS-232, RS-485, Ethernet RJ-45, Ethernet RJ-45/SFP, GPS/GLONASS

Regul R200 Programmable Logic Controller – Data Sheets

Functions of central processor unit modules in detail:

- Self-diagnostics, system configuration and working capacity check of functional modules
- Logical data processing and control signals output in accordance with the user's application program
- Data exchange with third party equipment via built-in interfaces
- Data storage in non-volatile memory
- Servicing of the real time clock including receiving of precise time signals via GPS/GLONASS
- Automatic reboot of the controller when power is supplied or in case of operation failures

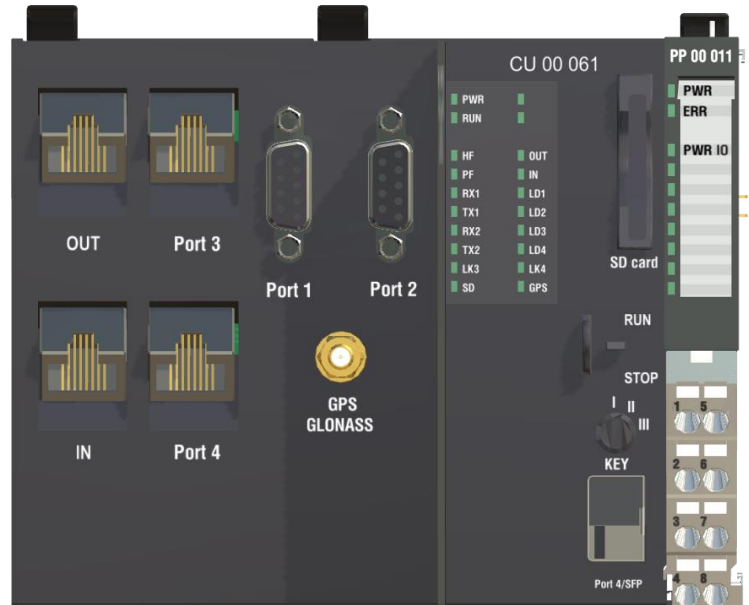

The module includes following:

- COM module and GPS/GLONASS module
- Power supply element of the real time clock
- Communication ports RS232, RS485, Ethernet
- Slot for SD memory cards
- Operation mode selector
- LED module and Power supply module



Regul R200 Programmable Logic Controller – Data Sheets

Table 1. Central processor unit modules: technical data

Parameter description, unit of measurement	Type of Module			
	00 021	00 031	00 041	00 061
RAM capacity, MB	512	512	512	512
ROM capacity, GB	1	1	1	1
Interfaces: <ul style="list-style-type: none"> • RS232 • RS485 • Ethernet • • GPS/GLONASS 	1 (COM1) 1 (COM2) 1xRJ45 —	1 (COM1) 1 (COM2) 1xRJ45 —	1 (COM1) 1 (COM2) 2xRJ45 1	1 (COM1) 1 (COM2) 1xRJ45, 1xRJ45/SFP 1
Absolute error limits of the internal clock, μ sec	defined by clock error of the higher-level server		± 50	± 50
Extension rack connection support	—	star connection	star and ring connection	
Absorbed power, W, maximum *	5	5,5	8,5	9
Operating temperature, °C	-40...+60 without condensate generation			
Storage temperature, °C	-55...+70	-55...+70	-55...+70	-55...+70
Ingress protection	IP20	IP20	IP20	IP20
Dimensions (WxHxD), mm	131x101x109		131x101x109	
Weight, kg	0.5	0.5	0.5	0.5

* Provided by the 24V DC power supply source (power supply arrangement is described in the section related to the PS module).



Input/Output Modules.

Input/output modules create an interface between the controller and the production process by means of mutual conversion of physical and logical signals.

The input/output, communication processor and power supply modules consist of three parts: **electronic unit**, **bus module** and **chassis**.

An **electronic unit** is an element with an indication module in the front. At the back side of electronic units, there are sockets: at the bottom – for external signals, and at the top – for internal power buses and data.

An electronic unit defines any module's functionality, application and, accordingly, its type. It carries out conversion of external signals into data to be transferred to the central processor and vice versa. Besides, an electronic unit carries out galvanic isolation of external channels from internal buses of the controller.

The electronic unit of the power supply module converts the power supply voltage into operating voltage (5V) of the internal power bus.

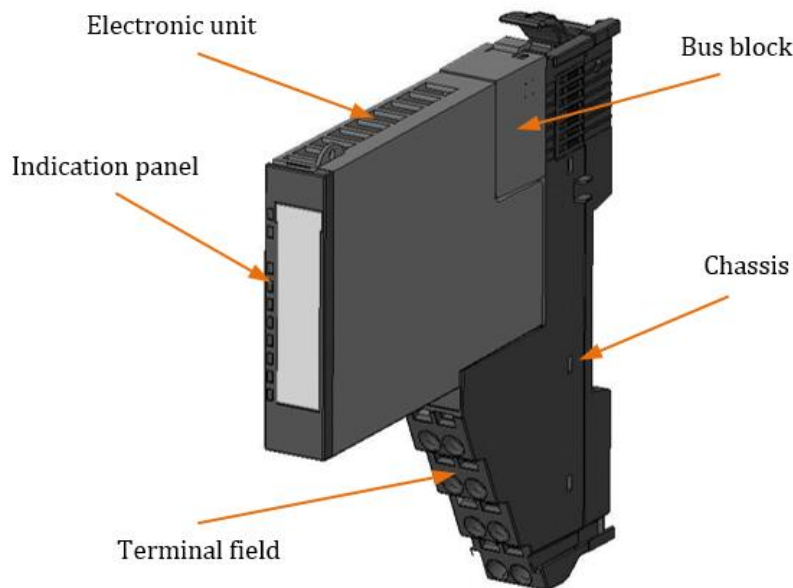

Figure 1. Module of the controller REGUL R200

Chassis and **bus modules** are similar in all the modules and interchangeable. The exception is the bus module of the power supply module.



Regul R200 Programmable Logic Controller – Data Sheets

The bus module is part of the internal data bus and enables the input/output module or the communication processor, inside which it operates, to be connected to the internal data bus of the controller.

The bus module of the power supply module is part of the controller power bus, but it does not belong to the controller data bus.

Chassis are designed for mechanical connection between the controller modules as well as between the modules and the DIN rails. They ensure switching of the internal data bus and form internal and external power buses of the controller.

Besides, chassis include a terminal field, to which all external signals are connected.

The chassis contain no electronic components, and they are an absolutely passive element.

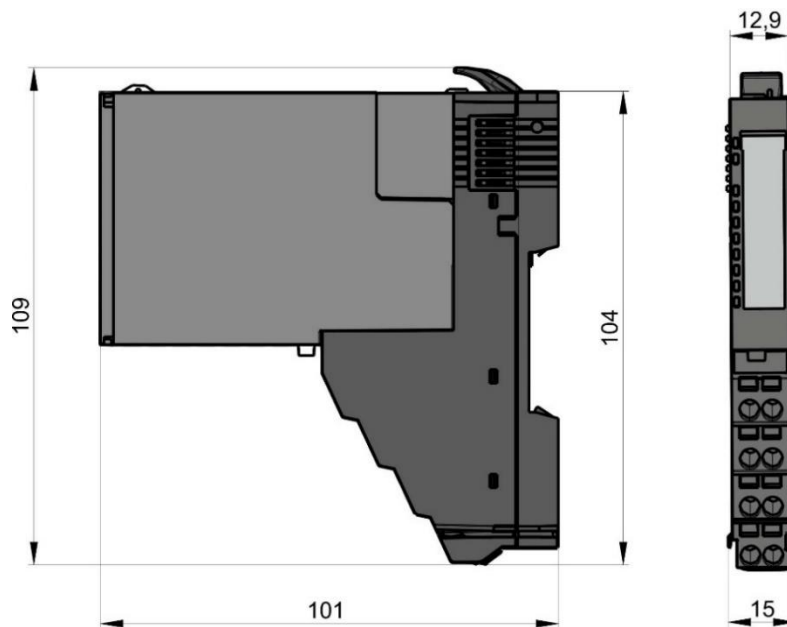

Figure 2. Overall dimensions of the power supply module

Power Supply Modules

Part number	Module description
R200 PP 00 011	Power supply module 24V DC 15W

Power Supply Module PP 00 011

Power supply modules perform the following functions:

- Power supply of internal consumers in the controller rack with stabilized 5V DC voltage
- Power supply of external circuits of the controller input/output modules with 24V DC voltage

Input voltage is connected via the terminal field of the chassis.

Terminals 4 (+) and 8 (-) receive 24 VDC voltage that is further distributed in two directions:

- For the conversion in the electronic unit of the power supply module into stabilized 5V voltage required for operation of the controller internal power bus that is designed for powering all internal electronic components of the controller, except components of the central processor module. Technical data of the internal power bus are shown in the Table 2.
- For power supply of the CPU module that uses internal converters to generate voltage levels required for its operation.

Terminals 2 (+) and 3 (-) receive 24 VDC voltage used for powering external circuits of input/output modules (external power bus). The maximum load across the external bus is 240 W. The input is protected from polarity reversal. All other power supply parameters (filtration, voltage stabilization, overvoltage protection, etc.) must be provided by the external power supply source. This power is supplied to all the controller modules located to the right from the power supply module. Power from this source is not supplied to the modules located to the left.

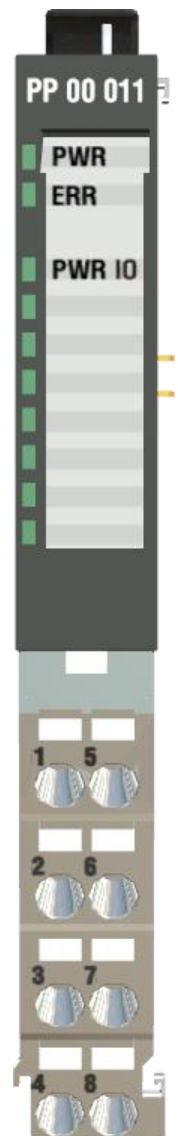



Regul R200 Programmable Logic Controller – Data Sheets

Table 2. Power supply module PP 00 011: technical data

Parameter description, unit of measurement	Value
Input DC voltage, V: <ul style="list-style-type: none">Nominal valuePermitted variation range	24 18...33
Input current, A, maximum	0.7 (at 24 V)
Output voltage, V	5
Nominal value of output power (power supplied to the internal power bus), W	15
Overvoltage protection	✓
Protection from polarity reversal	✓
Galvanic isolation of input and output circuits	—
Permitted potential difference between input and ground, V	1,500
Permitted peak voltage (100 ms), V	36
Operating temperature, °C	-40...+60 without condensate generation
Storage temperature, °C	-55...+70
Ingress protection	IP20
Dimensions (WxHxD), mm	12.9x101x109
Weight, kg	0.1

Indication

The LED panel of the module consists of following indicators:

- PWR – indicator is on when output voltage of 5 V supplied to the internal power bus is available.
- ERR – indicator is on in a situation when external supply of 24 V in terminals 4 (+) and 8 (-) is not available, but at the same time, the internal bus has voltage of 5 V supplied by another power supply source in the rack.
- PWR IO – indicator is on when voltage of 24 V is available in the external power bus.

Termination modules

Termination Module ST 00 011

Termination modules enable the extension rack R200 to be connected to the internal bus of the REGUL series controller. The termination module also includes a power supply module.

Part number	Module description
R200 ST 00 011	Termination module

Interface modules perform following functions:

- Connection of the extension rack R200 to the internal bus of the REGUL series controller
- Power supply of modules rack by means of the power supply module PP 00 011
- The module includes following items located in the front panel:
 - Two communication ports RJ-45 (IN and OUT) designed for providing communication between the controller racks
 - Address selector designed for setting the rack address in the distributed control system

Table 3. Termination module ST 01 011: technical data

Parameter description, unit of measurement:	Value
Absorbed power, W, maximum	2
Operating temperature, °C	-40...+60 without condensate generation
Storage temperature, °C	-55...+70
Ingress protection	IP20
Dimensions (WxHxD), mm	48.5x101x109

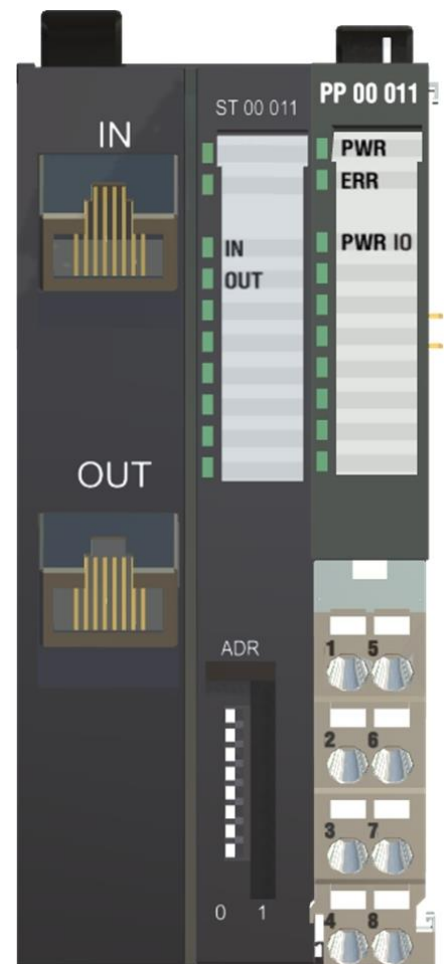



Regul R200 Programmable Logic Controller – Data Sheets

Parameter description, unit of measurement:	Value
Weight, kg	0.3

The address selector ADR consists of 8 DIP-keys. When a key is activated, the respective value (from 1 to 128) is added to the rack address and specified next to it. Eventually, the address selector can set any rack address in the range from 0 to 255.

Rack addresses can be set arbitrarily, without any reference to the physical order between the racks, but these addresses must coincide with the addresses assigned to these racks in the development environment Epsilon LD.

Indication

The functional indicators group of the LED panel of the module consists of following indicators:

- IN – indicator flashes in case there is some exchange via IN port
- OUT – indicator flashes in case there is some exchange via OUT port



Analog Input Modules

Part number	Module description
R200 AI 02 031	Analog input module, thermal resistor, thermocouples, 2 channels, common galvanic isolation
R200 AI 02 041	Analog input module, 0...20 mA, 4...20 mA, -10...+10 V, 0...+10 V, 2 channels, channel galvanic isolation, individual ADC for each channel
R200 AI 04 051	Analog input module, 0...20 mA, 4...20 mA, -10...+10 V, 0...+10 V, 4 channels, channel galvanic isolation, one ADC for all the channels

Regul R200 Programmable Logic Controller – Data Sheets

Analog Input Module AI 02 031

The module is designed for measuring of signals from resistance temperature detectors and thermocouples.

Two-/three-/four-wire connection diagrams of resistance temperature detectors are supported.

It is possible to connect to the module either two resistance temperature detectors, or a thermocouple with cold junction temperature measured by an external temperature sensor (resistance temperature detector) that can be connected to any of the module channels.

Compensation of cold junction temperature of thermocouples can be arranged by one of the three methods:

- Allocation of an individual channel to which a thermal resistor measuring the temperature in the cold junction point is connected
- Use of the temperature sensor integrated into the module
- Use of a preset temperature (to be preset in Epsilon LD during configuration of the system)

Types of sensors to be connected and connection diagrams are set separately for each of the channels.

There is no galvanic isolation between measuring channels of the modules.

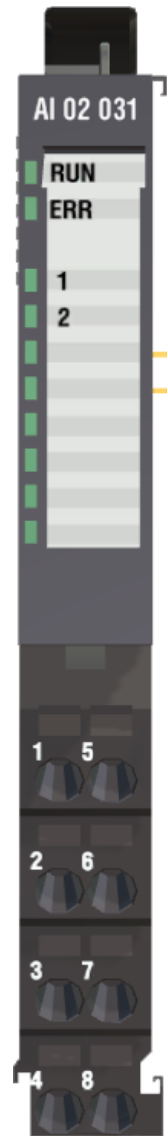

Table 4. Analog input module AI 02 031: technical data

Parameter description, unit of measurement:	Value
Number of channels	2
Bit depth (including overload area), bit	24
Measureable resistance range, Ohm	1...450
Types of supported resistance temperature detectors	see Table 1Table 5
Types of supported thermocouples	see Table 6



Regul R200 Programmable Logic Controller – Data Sheets

Parameter description, unit of measurement:	Value
Conversion time per channel, ms	see Table 7
Galvanic isolation, V <ul style="list-style-type: none">• between channels and the internal bus• between channels and supply voltage of the controller• between channels	1,000 1,000 —
Permitted potential difference between channels, V	30
Limits of permitted basic reduced resistance measuring uncertainty, %	0.1
Limits of permitted variation of resistance measuring uncertainty, %/0C	0.002
2-wire sensor connection	✓
3-wire sensor connection	✓
4-wire sensor connection	✓
Power input from the controller internal power bus, W, maximum	0.5
External supply voltage, V	24 (21.6...26.4)
Power input from the controller external power bus, W, maximum	0.2
Operating temperature, °C	-40...+60 without condensate generation
Storage temperature, °C	-55...+70
Ingress protection	IP20
Dimensions (WxHxD), mm	12.9x101x109
Weight, kg	0.1



Regul R200 Programmable Logic Controller – Data Sheets

Table 5. Measurement ranges of signals from resistance temperature detectors

Type of resistance temperature detectors:	Measuring range, °C:	Limits of permitted basic absolute uncertainty, °C:	
		Four-wire diagram:	Three-wire diagram:
50M ($\alpha=0.00428$)	from -180 to +200	± 0.5	± 0.7
100M ($\alpha=0.00428$)	from -180 to +200	± 0.5	± 0.7
50M ($\alpha=0.00426$)	from -50 to +200	± 0.5	± 0.7
100M ($\alpha=0.00426$)	from -50 to +200	± 0.5	± 0.7
50Π ($\alpha=0.00385$)	from -200 to +850	± 0.5	± 0.7
100Π ($\alpha=0.00385$)	from -200 to +850	± 0.5	± 0.7
Pt50 ($\alpha=0.00391$)	from -200 to +850	± 0.5	± 0.7
Pt100 ($\alpha=0.00391$)	from -200 to +850	± 0.5	± 0.7
50H ($\alpha=0.00617$)	from -60 to +180	± 0.5	± 0.7
100H ($\alpha=0.00617$)	from -60 to +180	± 0.5	± 0.7

Table 6. Measurement ranges of thermocouple signals

Type of thermocouples:	Measuring range, °C:	Limits of permitted basic absolute uncertainty, °C
R	from -50 to +1,760	± 3.0
S	from -50 to +1,760	± 3.0
B	from 500 to +1,820	± 2.5
J	from -210 to +1,200	± 2.5
T	from -200 to +400	± 1.5
E	from -200 to +1,000	± 2.0
K	from -250 to +1,370	± 2.5
N	from -200 to +1,300	± 2.5
A-1	from 0 to +2,500	± 3.0



Regul R200 Programmable Logic Controller – Data Sheets

Type of thermocouples:	Measuring range, °C:	Limits of permitted basic absolute uncertainty, °C
A-2	from 0 to +1,800	±3.0
A-3	from 0 to +1,800	±3.0
L	from -200 to +800	±2.0

Table 7. Conversion time

Phase:	Measuring time, ms:
Module temperature measuring	6
Measuring of line break for resistance	10 (I+, I-, U-) 230 (U+)
Measuring of resistance – 2- (4-) wire diagram:	
Smoothing level 1	130
Smoothing level 2	170
Smoothing level 3	210
Smoothing level 4	250
Smoothing level 5	332
Smoothing level 6	490
Measuring of resistance – 3-wire diagram:	
Smoothing level 1	254
Smoothing level 2	334
Smoothing level 3	416
Smoothing level 4	500
Smoothing level 5	660
Smoothing level 6	976



Regul R200 Programmable Logic Controller – Data Sheets

Phase:	Measuring time, ms:
Voltage measuring (thermocouple):	
Smoothing level 1	128
Smoothing level 2	168
Smoothing level 3	208
Smoothing level 4	252
Smoothing level 5	332
Smoothing level 6	492



Regul R200 Programmable Logic Controller – Data Sheets

Analog Input Module AI 02 041

The module is designed for input of two DC analog signals and/or DC voltage.

Signal measuring range is soft-/hardware configurable and it lies within the following ranges:

- From -10 to +10 V
- From 0 to +10 V
- From 0 to 20 mA
- From 4 to 20 mA

Measuring channels of the module are galvanically isolated.

The measuring channels are passive, i.e., power of analog circuits must be supplied from an external power source regardless of connection type.

The electronic unit of the module includes:

- 2 measuring blocks of input signals; each block includes an ADC and galvanic isolation elements
- Microprocessor
- Power supply unit
- Indication unit



Table 8. Analog input module AI 02 041: technical data

Parameter description, unit of measurement:	Value
Number of channels	2
Bit depth (including overload area), bit	24
Current measuring channels from 0 to 20 mA / from 4 to 20 mA:	
Standard input range, mA	0...20 / 4...20
Measureable range, mA	0...25
Permitted input current (setting of resettable fuse), mA	50
Input resistance, Ohm	100



Regul R200 Programmable Logic Controller – Data Sheets

Parameter description, unit of measurement:	Value
Voltage measuring channel from 0 to plus 10V:	
Input range, V:	
• Standard	0...10
• Measureable	0...11
Input resistance, kOhm, minimum	100
Voltage measuring channel from minus 10 to plus 10V	
Input range, V:	
• Standard	-10 ...+10
• Measureable	-11 ...+11
Input resistance, kOhm, minimum	100
General characteristics of measuring channels	
Conversion time per channel, ms	2.0
Conversion time per module (all channels are unlocked), ms	2.0
Galvanic isolation, V:	
• Between channels and the internal bus	1,000
• Between channels and supply voltage	1,000
• Between channels	1,000
Permitted potential difference between channels, B	1,000
Reverse polarity protection	✓
Limits of permitted basic reduced measuring uncertainty of DC voltage and DC current, %	0.025
Limits of permitted variation of measuring uncertainty of DC voltage and DC current, %/OC	0.002
2-wire sensor connection (passive sensor)	✓ (using external power supply)
4-wire sensor connection (active sensor)	✓
Power input from the controller internal power bus, W, maximum	0.5



Regul R200 Programmable Logic Controller – Data Sheets

Parameter description, unit of measurement:	Value
Power input from the controller external power bus, W, maximum	0.5
Operating temperature, °C	-40...+60 without condensate generation
Storage temperature, °C	-55...+70
Ingress protection	IP20
Dimensions (WxHxD), mm	12.9 x 101 x 109
Weight, kg	0.1

Analog Input Module AI 04 051

The module is designed for input of four DC analog signals and/or DC voltage.

The signal measuring range is soft-/hardware configurable, and it lies within the following ranges:

- From -10 to +10 V
- From 0 to +10 V
- From 0 to 20 mA
- From 4 to 20 mA

Measuring channels of the module are galvanically separated.

The measuring channels are passive, i.e., power of analog circuits must be supplied from an external power source regardless of connection type. The electronic unit of the module includes:

- 4 blocks for primary processing of input signals
- Multiplexor module
- Single ADC for all the channels
- Microprocessor
- Power supply unit
- Indication panel

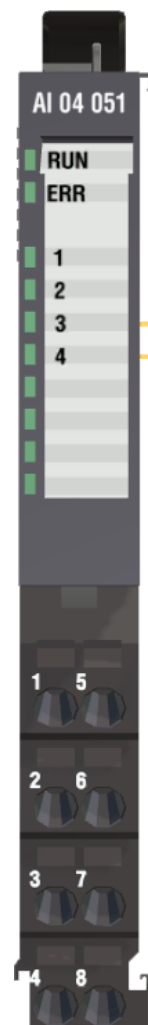



Regul R200 Programmable Logic Controller – Data Sheets

Table 9. Analog input module AI 04 051: technical data

Parameter description, unit of measurement:	Value
Number of channels	2
Bit depth (including overload area), bit	14
Current measuring channels from 0 to 20 mA / from 4 to 20 mA:	
Standard input range, mA	0...20 / 4...20
Measureable range, mA	0...25
Permitted input current (setting of resettable fuse), mA	30
Input resistance, Ohm	249
Voltage measuring channel from 0 to plus 10V:	
Input range, V: <ul style="list-style-type: none">• Standard• Measureable	0...10 0...10
Input resistance, MOhm, minimum	2
Voltage measuring channel from minus 10 to plus 10V:	
Input range, V: <ul style="list-style-type: none">• Standard• Measureable	-10 ...+10 -10 ...+10
Input resistance, MOhm, minimum	2
General characteristics of measuring channels:	
Conversion time per channel, ms	2.0
Conversion time per module (all channels are unlocked), ms	8.0
Galvanic isolation, V: <ul style="list-style-type: none">Between channels and the internal busBetween channels and supply voltage of the controllerBetween channels	1,000 1,000 250
Permitted potential difference between channels, B	250
Reverse polarity protection	✓



Regul R200 Programmable Logic Controller – Data Sheets

Parameter description, unit of measurement:	Value
Limits of permitted basic reduced measuring uncertainty of DC voltage and DC current, %	0.1
Limits of permitted variation of measuring uncertainty of DC voltage and DC current, %/0C	0.002
2-wire sensor connection (passive sensor)	✓ (using external power supply)
4-wire sensor connection (active sensor)	✓
Power input from the controller internal power bus, W, maximum	0.5
Power input from the controller external power bus, W, maximum	0.4
External supply voltage, V	24 (21.6...26.4)
Operating temperature, °C	-40...+60 without condensate generation
Storage temperature, °C	-55...+70
Ingress protection	IP20
Dimensions (WxHxD), mm	12.9 x 101 x 109
Weight, kg	0.1

Regul R200 Programmable Logic Controller – Data Sheets

Analog Input Module AI 04 011

The module is designed for input of four DC analog signals in the ranges from 0 to 20 mA, from 4 to 20 mA.

There is no galvanic isolation between measuring channels of the module.

The measuring channels are passive, i.e., power of analog circuits must be supplied from an external power source regardless of connection type.

The electronic unit of the module includes:

- 4 blocks for primary processing and generation of input signals
- Multiplexor
- ADC and galvanic isolation module
- Microprocessor
- Power supply unit
- Indication panel

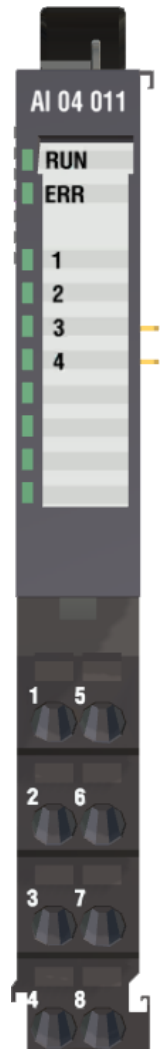

Table 10. Analog input module AI 04 011: technical data

Parameter description, unit of measurement:	Value
Number of channels	4
Bit depth (including overload area), bit	24
Standard input range, mA	0...20 / 4...20
Measureable range, mA	0...25
Permitted input current, mA	50
Input resistance, Ohm	100
Conversion time per channel, ms	2.0
Conversion time per module (all channels are unlocked), ms	8.0



Regul R200 Programmable Logic Controller – Data Sheets

Parameter description, unit of measurement:	Value
Galvanic isolation, V: <ul style="list-style-type: none">• Between channels and the internal bus• Between channels and supply voltage of the controller• Between channels	1,000 1,000 —
Permitted potential difference between channels, B	30
Reverse polarity protection	✓
Limits of permitted basic reduced measuring uncertainty of DC current, %	0.1
Limits of permitted variation of measuring uncertainty of DC current, %/°C	0.002
2-wire sensor connection (passive sensor)	✓ (using external power supply)
4-wire sensor connection (active sensor)	✓
Power input from the controller internal power bus, W, maximum	0.5
External supply voltage, V	24 (21.6...26.4)
Power input from the controller external power bus, W, maximum	0.3
Operating temperature, °C	-40...+60 without condensate generation
Storage temperature, °C	-55...+70
Ingress protection	IP20
Dimensions (WxHxD), mm	12.9 x 101 x 109
Weight, kg	0.1

Regul R200 Programmable Logic Controller – Data Sheets

Analog Input Module AI 04 081

The module is designed for receiving four analog DC signals in the ranges from 0 to 20 mA (without supporting the HART functions), in the range of 4 to 20 mA, including the possibility of data transmission over HART protocol.

There is no galvanic isolation between measuring channels of the module.

The measuring channels are passive, i.e., power of analog circuits must be supplied from an external power source regardless of connection type.

Each channel functions as the primary HART master device. All channels of the module can be used simultaneously by several clients and they can operate independently.

The module consists of:

- 4 blocks for initial processing and formation of input signals
- Measuring circuit consisting of ADP, multiplexor for the ADP, power supply unit and galvanic separation
- Configuration circuit consisting of the HART modem, multiplexor for the HART modem and galvanic separation
- Microprocessor
- Power supply for internal needs
- Indication panel



Table 11. Analog input module AI 04 081: technical data

Parameter description, unit of measurement:	Value
Number of channels	4
Bit depth (including overload area), bit	24
Standard input range, mA	0...20 / 4...20
Measureable range, mA	0...25
Permitted input current, mA	30
Input resistance, Ohm	250
Conversion time per channel, ms	2,0



Regul R200 Programmable Logic Controller – Data Sheets

Parameter description, unit of measurement:	Value
Conversion time per module (all channels are unlocked), ms	8,0
Galvanic isolation, V: <ul style="list-style-type: none">• Between channels and the internal bus• Between channels and supply voltage of the controller• Between channels	1,000 1,000 —
Permitted potential difference between channels, B	30
Reverse polarity protection	✓
Limits of permitted basic reduced measuring uncertainty of DC current, %	0.1
Limits of permitted variation of measuring uncertainty of DC current, %/°C	0.002
2-wire sensor connection (passive sensor)	✓ (using external power supply)
4-wire sensor connection (active sensor)	✓
Power input from the controller internal power bus, W, maximum	0.5
External supply voltage, V	24 (21.6...26.4)
Power input from the controller external power bus, W, maximum	0.3
HART communication: <ul style="list-style-type: none">• Single-point/multi-point connections• Primary/secondary master device	Yes/yes (up to 10 sensors) Primary only
Operating temperature, °C	-40...+60 without condensate generation
Storage temperature, °C	-55...+70
Ingress protection	IP20
Dimensions (WxHxD), mm	12.9 x 101 x 109
Weight, kg	0.1



Analog Output Modules

Part number	Module description
R200 AO 02 011	Analog output module, 0...20 mA, 4...20 mA, 2 channels, channel galvanic isolation

Analog Output Module AO 02 011

The module is designed for output of two DC analog signals in the ranges from 0 to 20 mA, from 4 to 20 mA.

The electronic block of the module includes:

- 2 digital-analog converters (DAC)
- 2 galvanic isolation elements (DC)
- Microprocessor
- Power supply unit of internal consumers
- Power supply unit of the DAC
- Indication panel

Table 12. Analog output module AO 02 011: technical data

Parameter description, unit of measurement:	Value
Number of channels	2
Bit depth (including overload area), bit	16
Standard output range, mA	0...20 / 4...20
Maximum generated current, mA	0...25
Load resistance, Ohm, maximum	500
Total signal setting time for all outputs, ms, maximum	5





Regul R200 Programmable Logic Controller – Data Sheets

Parameter description, unit of measurement:	Value
Galvanic isolation, V:	
Between channels and the internal bus	1,000
Between channels and supply voltage of the controller	1,000
Between channels	1,000
Permitted potential difference between channels, B	1,000
Reverse polarity protection supply voltage	—
Limits of permitted basic reduced playback uncertainty of DC current, %	0.1

Parameter description, unit of measurement:	Value
Limits of permitted variation of playback uncertainty of DC current, %/°C	0.0025
Power input from the controller internal power bus, W, maximum	0.5
External supply voltage, V	24 (21.6...26.4)
Power input from the controller external power bus, W, maximum	1.9
Operating temperature, °C	-40...+60 without condensate generation
Storage temperature, °C	-55...+70
Ingress protection	IP20
Dimensions (WxHxD), mm	12.9 x 101 x 109
Weight, kg	0.1

Digital Input Modules

Part number	Module description
R200 DI 08 011	Digital input module, 24 V DC, 8 channels

Digital Input Module DI 08 011

The module is designed for input of 8 digital 24V DC signals. First two channels out of the eight can be used for frequency measurement and pulse counting.

The electronic unit of the module includes:

- 8 blocks for receiving input digital signals with a common point; each channel is galvanically separated from the processing circuit
- Microprocessor
- Power supply unit
- Indication panel

Table 13. Digital input module DI 08 011: technical data

Parameter description, unit of measurement:	Value
Number of channels	8
Number of channels of frequency measurement and pulse counting	2 (first and second in sequence)
Frequency variation range, Hz	from 1 to 2500
Measuring range of pulse count	from 0 to 2 ⁶⁴ (showing signs of overflow)
Nominal DC voltage of the channel, V	24
Input voltage level, V: <ul style="list-style-type: none"> • For the '1' signal, minimum • For the '0' signal, maximum 	15 5
Permitted input DC voltage of the channel, V	30

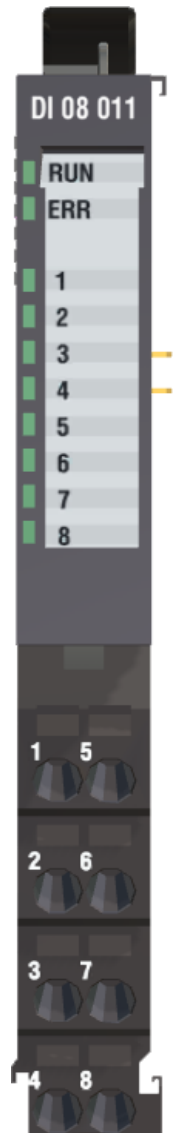



Regul R200 Programmable Logic Controller – Data Sheets

Parameter description, unit of measurement:	Value
Input current at '1' signal, mA, maximum	10

Parameter description, unit of measurement:	Value
Delay time, ms, maximum: <ul style="list-style-type: none">• From '0' to '1'• From '1' to '0'	1 1
Galvanic isolation, V: <ul style="list-style-type: none">• Between channels and the internal bus• Between channels and supply voltage of the controller	1,000 1,000
Permitted potential difference between channels, B	60
Limits of permitted relative frequency measuring error, %	0.01
Limits of absolute pulse counting error, pulse	±1
Power input from the controller internal power bus, W, maximum	0.5
External supply voltage, V	24 (20.4...28.8)
Power input from the controller external power bus, W, maximum	0.1
Operating temperature, °C	-40...+60 without condensate generation
Storage temperature, °C	-55...+70
Ingress protection	IP20
Dimensions (WxHxD), mm	12.9x101x109
Weight, kg	0.1

The module has the following operation algorithm: external 24V DC voltage is supplied to the sensor contacts. There is certain hardware in each channel to protect input circuits from overvoltage and overcurrent.

The module carries out initial processing of input signals: program filtration ('debouncing', the processing time for which is user defined in the setup parameters), direct galvanic isolation of circuits and TTL level signal generation.



GP SYSTEMS

Regul R200 Programmable Logic Controller – Data Sheets

Digital Output Modules

Part number	Module description
R200 DO 08 011	Digital output module 24 V DC, 0.5 A, 8 channels

Digital Output Module DO 08 011

The module is designed for output of 8 24V DC digital signals.

The electronic unit of the module includes:

- 8 dry contact type output signal blocks, each channel is galvanically separated from the processing circuit
- Microprocessor
- Power supply unit
- Indication panel

Table 14. Digital output module DO 08 011: technical data

Parameter description, unit of measurement:	Value
Number of channels	8
Nominal DC voltage of the channel, V	24
Permitted applied DC voltage, V	30
Maximum load current of the channel, A	0.5
Leakage current, mA, maximum	1
Delay time (for ohmic load), ms, maximum: <ul style="list-style-type: none"> • From '0' to '1' • From '1' to '0' 	2 2
Galvanic isolation, V: <ul style="list-style-type: none"> • Between channels and the internal bus • Between channels and supply voltage 	1,000 3,000
Voltage surge protection	✓ (>33V)

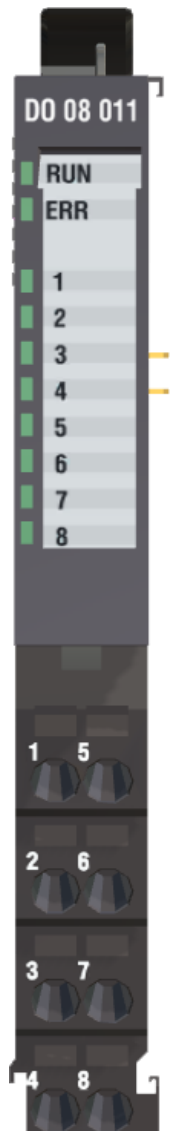



Regul R200 Programmable Logic Controller – Data Sheets

Parameter description, unit of measurement:	Value
Short circuit protection	✓
Overvoltage protection	—
Power input from the controller internal power bus, W, maximum	0.5
External supply voltage, V	24 (20.4...28.8)

Parameter description, unit of measurement:	Value
Power input from the controller external power bus, W, maximum	0,3
Operating temperature, °C	-40...+60 without condensate generation
Storage temperature, °C	-55...+70
Ingress protection	IP20
Dimensions (WxHxD), mm	12.9x101x109
Weight, kg	0.1

The module has the following operation algorithm: the microprocessor receives from the application program a status mask of output signals and sends respective control signals to the relays switching external power circuits. Upon receipt of the channel status signal, the microcontroller turns on the respective LED indicators.

When the module loses communication with the central processor, channels control can consist of several configurable phases (maximum – 3 phases with the possibility of cyclical repetition) with different intervals (maximum – 65.535 seconds per interval) and different control strategies at each phase. Setup parameters are described in **Error! Reference source not found.**

Counter Modules

Part number	Module description
R200 DA 01 011	Pulse count module, 1 count channel, 1 Hz – 500 kHz, galvanic isolation of the count channel, 2 digital 24V DC input channels, 2 24V DC 0.5A digital output channels

Counter Module DA 01 011

The module is designed for input of one channel of 1 to 500,000Hz pulse signals, nominal signal voltages – 5V, 12V, 24V.

The module can operate in one of the following modes (set in the program environment Epsilon LD):

- Frequency meter up to 10 kHz including pulse counting and external power supply indication
- Frequency meter up to 500kHz including external power supply indication
- Module of an oil quality and quantity measurement system (OQQMS) including external power supply indication
- Automatic safety device without frequency generator

The electronic unit of the module includes:

- Frequency measuring controller
- Receiving block of digital input signals, each channel is galvanically separated from the processing circuit
- Dry contact type sending block of output relay signals; each channel is galvanically separated from the processing circuit
- Microprocessor
- Power supply unit
- Indication panel





Regul R200 Programmable Logic Controller – Data Sheets

Table 15. Counter module AI 04 011: technical data

Parameter description, unit of measurement:	Value
Number of channels of frequency measurement and pulse counting	1
Frequency variation range, Hz	from 1 to 500,000
Measuring range of pulse count	from 0 to 2 ⁶⁴ (showing signs of overflow)
Pulse time, µsec, minimum	1
Pause time, µsec, minimum	1
Nominal input voltage of frequency measurement and pulse count channel, V	5, 12, 24
Permitted input voltage, V	30
Input resistance, kOhm, minimum	100
Parameters of frequency measurement and pulse count channel with nominal voltage of 5V:	
Input voltage level, V:	
• For the '1' signal, minimum	4
• For the '0' signal, maximum	3
Parameters of frequency measurement and pulse count channel with nominal voltage of 12V:	
Input voltage level, V:	
• For the '1' signal, minimum	8
• For the '0' signal, maximum	6
Parameters of frequency measurement and pulse count channel with nominal voltage of 24V	
Input voltage level, V:	
• For the '1' signal, minimum	18
• For the '0' signal, maximum	14
Digital inputs	
Number of digital inputs	2
Nominal DC voltage of the channel, V	24



Regul R200 Programmable Logic Controller – Data Sheets

Parameter description, unit of measurement:	Value
Input voltage level, V: <ul style="list-style-type: none">• For the '1' signal, maximum range• For the '0' signal, maximum	6...30 3
Current limit, mA	5
Permitted input voltage, V	30
Delay time, µsec: <ul style="list-style-type: none">• From '0' to '1'• From '1' to '0'	<<1 <<1
Digital outputs	
Number of digital outputs	2
Nominal DC voltage of the channel, V	24
Load current of the channel, A, maximum	0.5
Delay time (for ohmic load), ms: <ul style="list-style-type: none">• From '0' to '1'• From '1' to '0'	0.5 0.1
Galvanic isolation, V: <ul style="list-style-type: none">• Between channels and the internal bus• Between channels and supply voltage	1,000 1,000
Short circuit protection	✓
Limits of permitted relative frequency measuring error, %	0.01
Limits of absolute pulse counting error, pulse	±1
Power input from the controller internal power bus, W, maximum	0.6
External supply voltage, V	24 (21.6...26.4)
Power input from the controller external power bus, W, maximum	0.5
Operating temperature, °C	-40...+60 without condensate generation
Storage temperature, °C	-55...+70



Regul R200 Programmable Logic Controller – Data Sheets

Parameter description, unit of measurement:	Value
Ingress protection	IP20
Dimensions (WxHxD), mm	12.9x101x109
Weight, kg	0.1

Frequency controller

The frequency controller measures signal parameters of frequency inputs (frequency, running sum, etc.) depending on the preset algorithm (operation mode).

LACT (Lease Automatic Custody Transfer) Mode

A system for operating a lease automatic custody transfer (LACT) unit could be configured with the use of REGUL RX00 modules, including pulse count module with LACT mode firmware. The system is used to measure, calculate, control, store parameters of oil flow rate, pressure, pressure drop, temperature, as well as oil qualitative (density, viscosity, moisture) and quantitative (volume, weight) data.

The pulse count module in the system receives pulse frequency signals in the range from 1 to 10,000 Hz from turbine flow rate meters and density meters.

Electronic Overspeed Trip (EOT) mode

Electronic overspeed trip is designed for protection of the turbine against critical RPM values when the load is dropped. The EOT measures input electrical signals via three independent channels (R200 DA 01 011 modules are connected), compares the results with the emergency setting, and when the critical RPM value is reached a signal is issued to stop the turbine taking into consideration its acceleration, i.e., if certain acceleration is present, the EOT re-calculates and decreases the setting to avoid the RPM higher than the critical value. The EOT enables following functions to be performed:

Data acquiring from the sensors of the turbine rotor RPM via three independent channels (signals from three sensors must be available for stable operation of the EOT)

- Calculation of current rotation acceleration values of the turbine rotor
- Calculation of a trip setting taking into consideration the current rotation acceleration value of the turbine rotor
- Storage in the volatile memory of RPM values at which control signals were generated



Regul R200 Programmable Logic Controller – Data Sheets

- Continuous functional checking of the measuring channels
- Creation of an emergency event archive and record keeping of all events including provisions for event log viewing

The module inputs and outputs are configured in the Epsilon LD programming environment. Setup parameter values are stored in the volatile memory of the module.

Digital input configuration

There are provisions in the programming environment for assigning functional purposes to each digital input; types of functional purposes are listed in the table (Table 16). Type 1 functional purposes are assigned to one or two inputs. Digital inputs may also have Types 2 or 3 functional purposes.

In case Type 1 has not been selected, all digital inputs will have type 2 functional purposes, and the diagnostics function of protective relays is automatically locked.

Table 16. Functional purpose types of digital inputs

Nº:	Type	Description
1	Checkback of protective relay activation	This type of input is designed for receiving activation control signals of the protective relay controlled by the 'Protective Relay Activation' output. Signal status is used in the protective relay diagnostics algorithm.
2	Arbitrary checking	This type of input is designed for receiving a signal whose status is not analyzed in the protection and diagnostics algorithm of the module; rather, it is simply sent to the CP application software.
3	Power supply in the protection circuits	This type of input is designed for receiving power loss signals in the protection circuits. Power loss is indicated by the 0 signal level at the input of the module. Signal status is used in the protection activation algorithm.

Digital output configuration

There are provisions in the programming environment for assigning purposes to each digital output; functional purpose types are listed in the table (Table 17). By default, digital outputs are assigned Type 5 functional purposes.



Regul R200 Programmable Logic Controller – Data Sheets

Table 17. Functional purpose types of digital outputs

Nº:	Type	Description
1	Protection tripping	This type of output indicates that conditions are in place for tripping of the protection (logical level 1). It is used for external alarm
2	Enabling/disabling of the protective relay	This type of output controls the protective relay after tripping of the protection (logical level 1 or 0, to be selected when the protection algorithm is configured)
3	High frequency	This type of output is designed for generating alarms when the rotor RPM value used in the protection algorithm exceeds the warning threshold value (logical level 1)
4	Failure	This type of output indicates that the frequency value is not true, there is a failure of the module or any of the protective relays (logical level 1)
5	Arbitrary control	The output status of this type is not generated in the protection and diagnostics algorithms of the module; it is set up in the CP application software.

Frequency input configuration

There are provisions in the programming environment for assigning functional purposes to the frequency input; functional purpose types are listed in the table (Table 18). By default, the frequency input has Type 2 functional purpose.

In case no Type 1 channel has been selected, all frequency inputs have Type 2 functional purposes, and the functions of overspeed protection and diagnostics are disabled automatically.

Table 18. Functional purpose types of frequency inputs

Nº	Type	Description
1	Protective measurement	This type of input is designed for receiving a frequency signal based on which the rotor RPM and angular acceleration values that are used in the protection and diagnostics algorithms are calculated



Regul R200 Programmable Logic Controller – Data Sheets

№	Type	Description
2	Arbitrary measurement	This type of input is designed for receiving a frequency signal based on which the rotor RPM and angular acceleration values that are not used in the protection and diagnostics algorithms are calculated

Microprocessor functions

The microprocessor performs following functions depending on the preset algorithm (operation mode):

- Control signal generation for digital outputs
- Status polling of digital inputs
- Data exchange with the frequency controller (processed data reading in measuring channels, statuses of digital inputs/outputs, operation mode transfer, settings, etc.)
- Signal generation for the module indication panel

Communication Processor Modules

Part number	Module description
R200 CP 01 011	Communication processor module RS485 (Modbus RTU), 1 port

Communication Processor Module CP 01 011

The communication processor module CP 01 011 is designed for providing an independent communication channel via RS-485 interface. The module contains no protocol drivers. It carries out physical connection of external devices. Protocol drivers for data transfer via these channels function in the central processor module.

Table 19. Communication processor module CP 01 011: technical data

Parameter description, unit of measurement:	Value
Number of ports	1
Implemented protocols	IEC 60870-5-101 (Master/Slave) Modbus RTU (Master/Slave)
Data transfer rate, bit/sec	150...115,200
Galvanic isolation, V <ul style="list-style-type: none"> between channels and the internal bus between channels and supply voltage of the controller 	1,000 1,000
Power input from the controller internal power bus, W, maximum	0.6
Power input from the controller external power bus, W, maximum	0
Operating temperature, °C	-40...+60 without condensate generation





Regul R200 Programmable Logic Controller – Data Sheets

Parameter description, unit of measurement:	Value
Storage temperature, °C	-55...+70
Ingress protection	IP20
Dimensions (WxHxD), mm	12.9x101x109
Weight, kg	0.1

Functional indicators group of the module LED panel consists of indicators RX and TX, which indicate data receiving or sending in the channel.



GP SYSTEMS

Regul R200 Programmable Logic Controller – Data Sheets



GP SYSTEMS

GP Systems GmbH

Ochshäuser Str., 45
34123 Kassel Germany

Phone: +49 561 820 93350

Fax: +49 561 820 93351

General inquiries: info@gp-systems.com

Technical support: support@gp-systems.com

Website: <https://automation.gp-systems.com>